

Write your name here

Surname

Other names

Edexcel
Functional Skills

Centre Number

--	--	--	--	--

Candidate Number

--	--	--	--	--

Mathematics

Level 2

Mock Test 11



9–13 May 2011

Time: 1 hour 30 minutes

Paper Reference

FSM02/01

You must have:

Pen, calculator, HB pencil, eraser, ruler graduated in cm and mm, protractor, compasses.

Total Marks

Instructions

- Use **black** ink or ball-point pen.
- **Fill in the boxes** at the top of this page with your name, centre number and candidate number.
- Answer **all** questions.
- Answer the questions in the spaces provided
– *there may be more space than you need.*
- **Calculators may be used.**

Information

- The total mark for this paper is 48.
- The marks for **each** question are shown in brackets
– *use this as a guide as to how much time to spend on each question.*
- **Where you see this sign you must show clearly how you get your answers because marks will be awarded for your working out.**

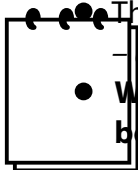

Advice

- Read each question carefully before you start to answer it.
- Show all stages in the calculations.
- Keep an eye on the time.
- Try to answer every question.
- Check your answers if you have time at the end.

Turn over ►

P39465RA

©2011 Edexcel Limited.

6/4/3/2



P 3 9 4 6 5 R A 0 1 2 0

edexcel 
advancing learning, changing lives

SECTION A: Sports centre

Answer all questions in this section.

Write your answers in the spaces provided.

- 1 Praveen is the manager of a sports centre.
She uses these staff at the swimming pools.

Name	Hours per day
Andy	4
Mary	4
Pat	3
Jo	3
Shanie	$2\frac{1}{2}$

Praveen pays these staff £7.08 per hour.

(a) What is the total amount she pays these staff per day?

(2)

Use the box below to show clearly how you get your answer.

(b) Show how you can check your answer to (a).

(1)

Write your check in the box below.



The sports centre has two swimming pools.
There is a main pool and a learner pool.

Praveen needs to plan the Early session, the Evening session and the Late session.

The table below shows when Praveen needs her staff at the swimming pools.

Session	Time	Main pool	Learner pool
Early	06:00 – 08:30	2 staff	closed
Evening	17:30 – 20:00	2 staff	1 staff
Late	20:00 – 22:00	2 staff	closed

These are the hours her staff work each day.

Name	Hours per day
Andy	4
Mary	4
Pat	3
Jo	3
Shanie	$2\frac{1}{2}$

Praveen needs a staff rota for next Monday.

The staff rota must show

- the staff who are working
- the times they are working
- the pool where they are working.

(c) Make a staff rota for Praveen.

(3)

Use the box below to show your rota clearly.

(Total for Question 1 is 6 marks)



2 Praveen needs to put an extra ramp for wheelchair access at a side door. Here is a sketch of the ramp.

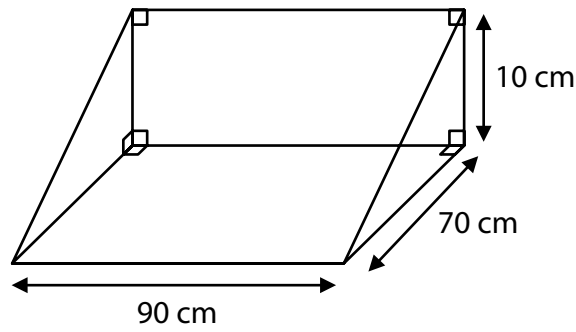
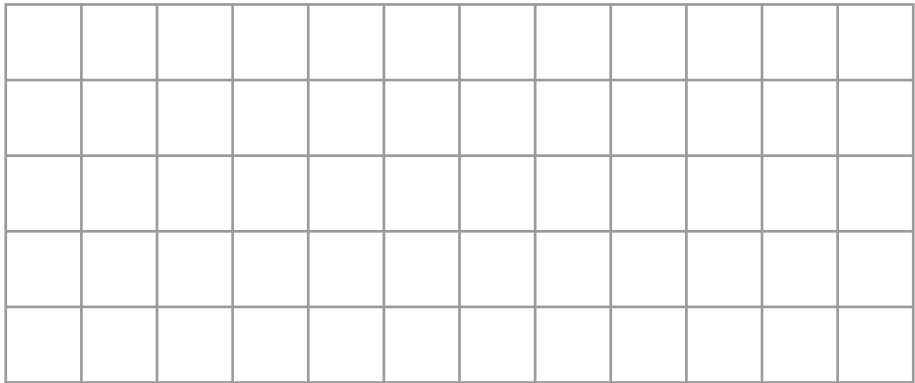

Diagram **NOT** accurately drawn

Praveen wants to see how steep the ramp is.

(a) Draw an accurate side view of the ramp. (2)

Use the grid to draw the side view.



Key: 1 cm on the grid is 10 cm on the ramp.

Praveen wants to know how many adults and how many children use the sports centre at different times of day.

She needs a data collection sheet.

The sheet must have space for

- the day
- the time
- the number of adults **and** the number of children.

(b) Design a data collection sheet for Praveen. (3)



Use the box below to show your data collection sheet.

A large, empty rectangular box with rounded corners, intended for students to draw or write their data collection sheet.

(Total for Question 2 is 5 marks)



3 Dil is a football coach.
He wants to book the sports hall on a Saturday morning for a football competition.

The hall is usually booked for playing badminton on a Saturday morning.

Praveen will only book the hall for football if she can charge more than she usually gets for badminton.

She knows that

5 badminton courts are usually fully booked for 3 hours

Charge for badminton court for 1 hour	
Centre member	£9.80
Not a centre member	£12.40

$\frac{2}{3}$ of the bookings are usually from centre members

$\frac{1}{3}$ of the bookings are usually from people who are not centre members

Praveen decides to charge Dil 25% more than she usually gets for badminton.

How much money should Praveen charge Dil?

(5)

Use the box below to show clearly how you get your answer.

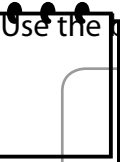

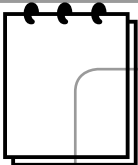

A large, empty rectangular box with rounded corners, intended for the student's answer to Question 3.

(Total for Question 3 is 5 marks)



P 3 9 4 6 5 R A 0 7 2 0

SECTION B: Holiday

Answer all questions in this section.

Write your answers in the spaces provided.

- 4 Clare is flying on holiday to America.
She can take a bag that weighs up to 23 kg on the flight.

Clare weighs her bag on her bathroom scales.
The bag weighs 48.2 lbs.

$$1 \text{ kg} = 2.2 \text{ lbs}$$

(a) Can Clare take this bag on the flight?

(2)

Use the box below to show your answer.

Clare buys these items on the flight.

Camera	£199
Sunglasses	£ 85
Make-up	£ 97

Clare will get 10 airmiles for every £5 she spends.

Clare wants to use airmiles to fly to Paris later in the year.
She needs 750 airmiles for the flight to Paris.

(b) Will Clare get enough airmiles for the flight to Paris?

(3)



Use the box below to show clearly how you get your answer.

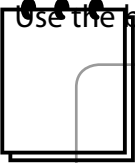

Clare paid £199 for the camera on the flight.

She sees the same type of camera in a shop in America.

The price of the camera in the shop is \$335

Clare thinks the price on the flight is cheaper than the price in the shop.

Use £1 = \$1.62

(c) Is Clare correct?

Show why you think this.

(3)

Use the box below to show clearly how you get your answer.

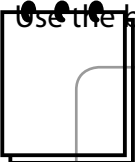

(Total for Question 4 is 8 marks)



5 Clare will spend two days of her holiday in New York.

These are the activities Clare wants to do.

Activity	When available	Cost (\$)
Food tour	afternoon or evening	36
River cruise	afternoon or evening	34
Bronx zoo	morning or afternoon	16
Basketball	evening	48
Ellis Island	morning or afternoon	22
Baseball	afternoon or evening	55
Jazz club	evening	40
Museum	morning or afternoon	20
Broadway tour	morning or afternoon	18

Clare has a budget of \$130 to spend on activities.

She wants to do 5 **different** activities in these sessions

- Day 1, afternoon
- Day 1, evening
- Day 2, morning
- Day 2, afternoon
- Day 2, evening

Make a plan for Clare.

It must show the sessions, the activities and the total cost.

Plan activities for Clare in New York.

(3)



Use the box below to show your plan clearly.



(Total for Question 5 is 3 marks)



- 6 Clare plans to hire a car and drive from New York to Connecticut. The map below shows the roads between New York and Connecticut.

Clare uses her ruler.

She marks the map with the approximate route she will drive.

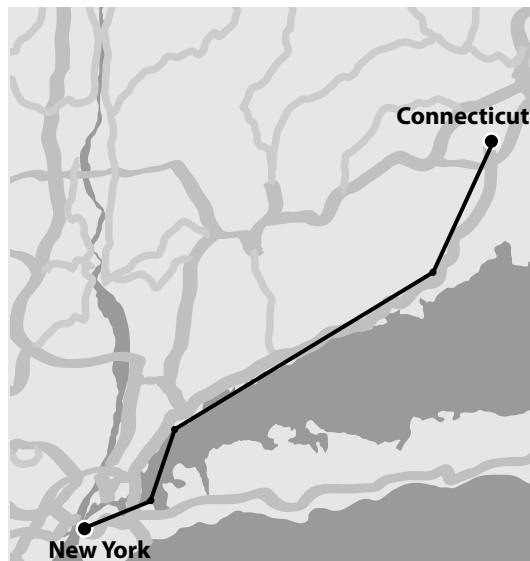

Scale: 1 cm represents 20 km

Clare hires the car in New York.

The car does 50 km per gallon of fuel.

A full tank holds 10 gallons of fuel.

When she gets the car the fuel gauge shows the tank is half full.

Does the car have enough fuel in the tank for the journey from New York to Connecticut?

(5)



Use the box below to show clearly how you get your answer.

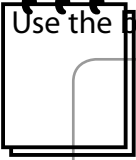

A large, empty rectangular box intended for the student to show their working out for the answer.

(Total for Question 6 is 5 marks)



SECTION C: Rented houses

Answer all questions in this section.

Write your answers in the spaces provided.

- 7** Jim works for an estate agent.
His office is in Cove.
On Thursday he has to visit three other towns.

The table below shows information about what Jim has to do on Thursday.

Town	Type of work	Time allowed
Cove	office work	1½ hours
Ash	2 house visits	30 minutes each
Hook	1 inventory	2½ hours
Frimley	1 maintenance check	1 hour

Jim starts work and finishes work at his office in Cove.
He starts work at 9 am.

Jim wants 30 to 45 minutes for his lunch break.
He has to meet a client in Ash at 1 pm for the 2 house visits.

The diagram below shows the times he needs for travelling.

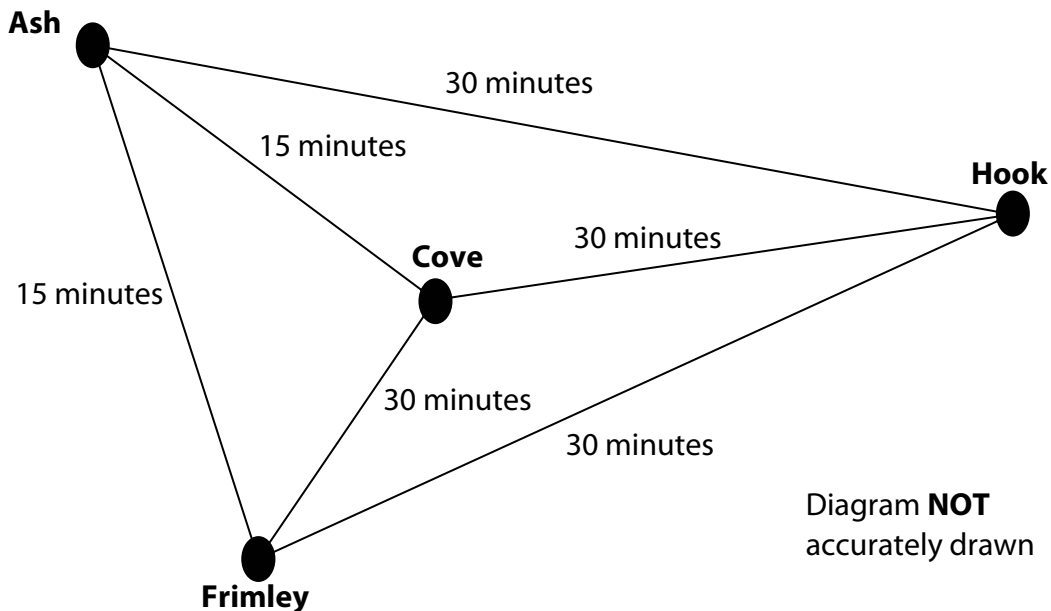

Jim needs a plan to fit in all his work on Thursday.
The plan must show the time he wants to arrive at each town and leave each town.
It must also show the time for his lunch break and the time he will finish work.

Plan Thursday's work for Jim.

(5)



Use the box below to show your plan.



(Total for Question 7 is 5 marks)



8 The estate agent has two types of service for rented houses.

The rules below show the fee the estate agent charges for each type of service.

Service A

Full management of rented house

$$F = 500 + 0.96R$$

F is the fee in pounds (£)
R is the monthly rent in pounds (£)

Service B

Rent collection only

$$F = 0.6R$$

F is the fee in pounds (£)
R is the monthly rent in pounds (£)

The monthly rent for one house is £650

Calculate and compare the fees for the two types of service for this house.

(3)

Use the box below to show clearly your answers and your comparison.

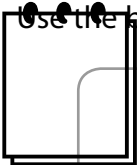

(Total for Question 8 is 3 marks)



9 Jim has to prepare a report for the estate agent.

The table shows the fees paid to the estate agent for rented houses in each three-month period for the last two years.

	Jan – Mar	Apr – Jun	Jul – Sept	Oct – Dec
2009	£14 100	£16 500	£14 600	£14 800
2010	£14 500	£16 200	£15 600	£14 900

Jim has to interpret the information.

Jim needs to compare the fees paid to the estate agent in each three-month period in 2009 with the fees paid in 2010

(a) Write **two** statements to compare the fees paid in 2009 with the fees paid in 2010

(2)



Here is the table of fees again.

	Jan – Mar	Apr – Jun	Jul – Sept	Oct – Dec
2009	£14 100	£16 500	£14 600	£14 800
2010	£14 500	£16 200	£15 600	£14 900

Jim needs a graph or chart to display the fees for each three-month period in 2009 and 2010

(b) Draw a graph or chart for Jim.

(3)

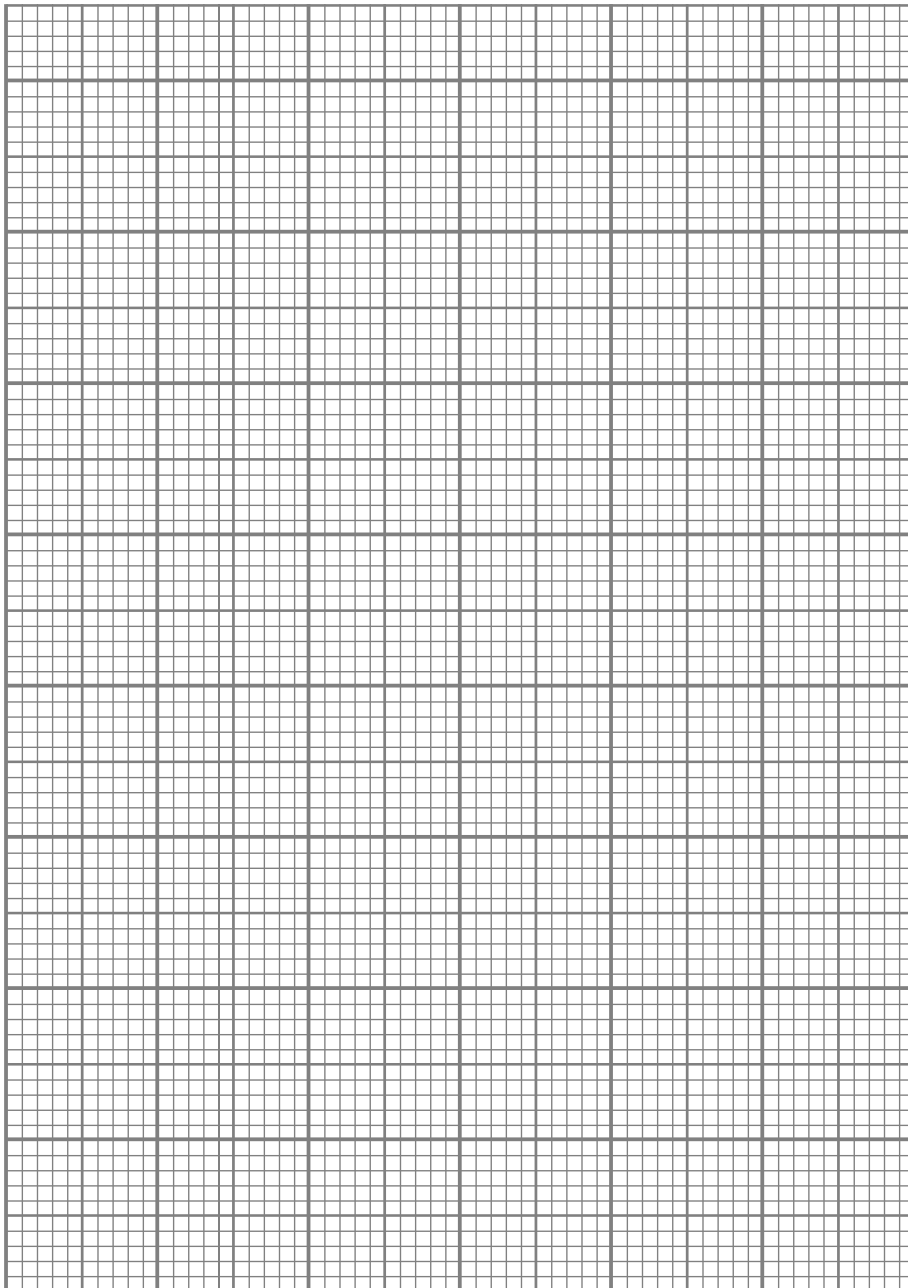

Jim calculates that the total fees paid in 2010 are 2% higher than in 2009

(c) Is Jim correct?
Show why you think this.

(3)

Use the box below to show clearly your check and your answer.

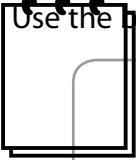

(Total for Question 9 is 8 marks)

TOTAL FOR PAPER IS 48 MARKS



BLANK PAGE

